

Technical data sheet



Product features

Induction hob counter top electric 12 power levels digital control panel 230 V

Model	SAP Code	00011148
--------------	-----------------	----------

– Control type: Digital



SAP Code	00011148	Net Weight [kg]	4.30
Net Width [mm]	330	Power electric [kW]	3.500
Net Depth [mm]	420	Loading	230 V / 1N - 50 Hz
Net Height [mm]	100		

Technical data sheet

Technical drawing



Induction hob counter top electric 12 power levels digital control panel 230 V

Model	SAP Code	00011148
-------	----------	----------

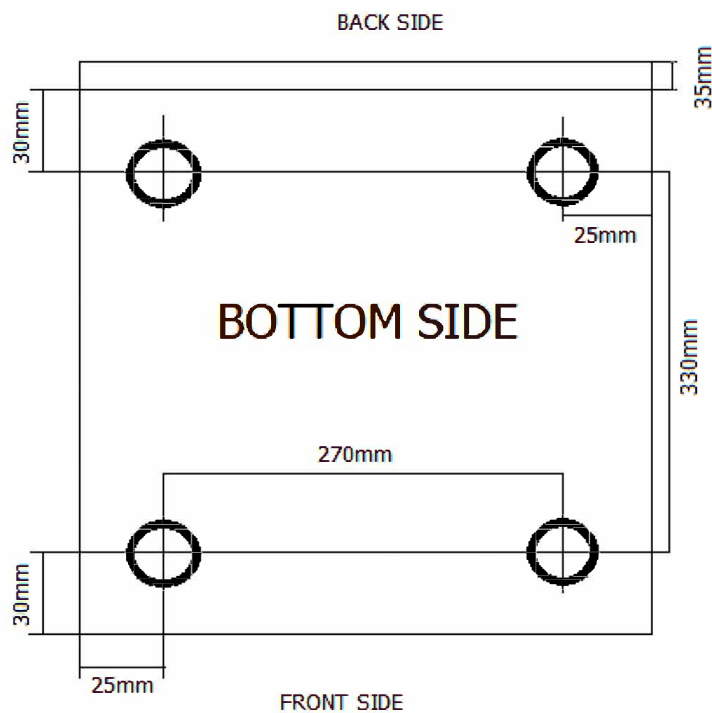
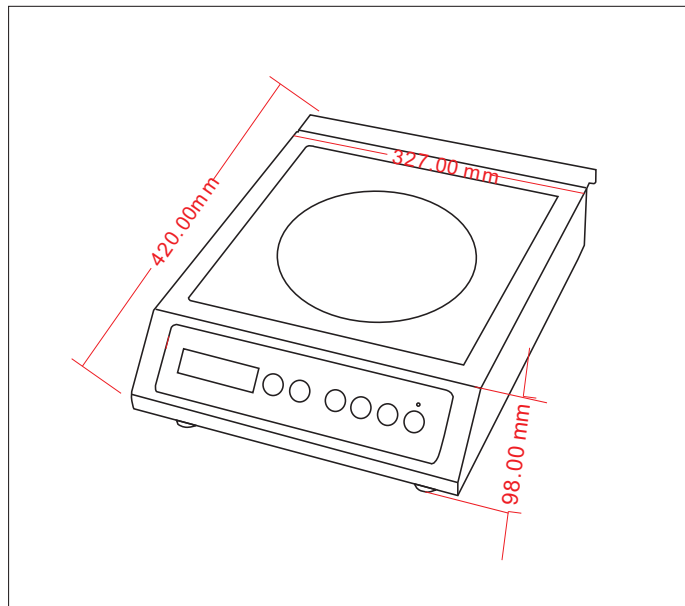

Technical data sheet



Product benefits

Induction hob counter top electric 12 power levels digital control panel 230 V

Model	SAP Code	00011148
--------------	-----------------	----------

- 1 Power consumption 3.5kW**
high performance
 - fast heating
- 2 Induction heating**
heating efficiency
 - cost and time saving
- 3 All-stainless design**
ensuring long life
high hygiene standard
 - safe and safe food preparation; long service life;
easy cleaning facilitates compliance with hygiene standards (HACCP)
- 4 Digital control**
precise control
 - less control error
 - more comfortable operation
- 5 LED Display**
legible power settings
 - less control error
- 6 Table version**
easily portable
 - can be placed anywhere on the table

Technical data sheet



Technical parameters

Induction hob counter top electric 12 power levels digital control panel 230 V

Model	SAP Code	00011148
--------------	-----------------	----------

1. SAP Code:

00011148

8. Gross Height [mm]:

150

2. Net Width [mm]:

330

9. Gross Weight [kg]:

5.50

3. Net Depth [mm]:

420

10. Device type:

Electric unit

4. Net Height [mm]:

100

11. Power electric [kW]:

3.500

5. Net Weight [kg]:

4.30

12. Loading:

230 V / 1N - 50 Hz

6. Gross Width [mm]:

380

13. Control type:

Digital

7. Gross depth [mm]:

500

14. Cross-section of conductors CU [mm²]:

1

- Výkon (kW): 3,7-5 (230 V); 6,4-8,7 (400 V)